

Enhancing Environment of Smart City Using Iot Approach

Shriya.U.Rahate¹, Dr. Narendra G. Bawane²

¹(M. Tech VLSI, Jhulelal Institute of Technology, RTMNU Nagpur)

²(Principal, Jhulelal Institute of Technology, RTMNU, Nagpur)

Abstract: Nowadays internet of thing has changed people way of using technology. Devices operating using internet has evolved over the last few years. Due to the advancement of sensor technology the way of working has improved a lot that is speed, performance. In this project I am developing a system smart city that is equipped with Internet of Things. In this System four modules are used such as, environmental parameter, accident detection, road signage, school/hospital. This system will help to improve the smart environment conditions and provide a better way of living. Thus our system will make the city better than the existing smart cities that are available.

Keywords: IOT, Smart city, LM35, 8051microcontroller, PIC, Pollution Sensor, Ultrasonic sensor, Zigbee.

I. Introduction

Internet of thing (IoT) has changed people way of using technology. Devices operating using internet has evolved over the last few years. Due to the advancement of sensor technology the way of working has improved a lot that is speed, performance. In this project I am developing a system "SMART CITY" that is equipped with Internet of Things. It will also facilitate with different features like environmental parameter, accident detection, road signage, school/hospital. This system will help to improve the smart environment conditions and provide a better way of living. Thus this system will make the city better than the existing smart cities that are available.

Smart cities will incorporate information and communication technologies which enhance city functions and the quality of life of its citizens. And hence from these technologies it should minimize the use of resources, avoid wastage, and reduce overall costs.

Some technologies used to make cities smart are sensors which help manage streetlights and traffic signals.

The Internet of Things (IoT) is a recent communication paradigm that aims at making the Internet even more immersive and pervasive. Furthermore, by enabling easy access and interaction with a wide range of devices such as, for instance, home appliances, surveillance cameras, monitoring sensors, actuators, displays, vehicles, and so on, the IoT will faster the development of a number of applications that make use of the potentially large amount and variety of data generated by such objects to provide new services to citizens, companies, and public administrations.

Environmental change is affecting cities and their inhabitants more regularly. This brings new challenges for city planners, such as the need to improve air and water quality, and control noise pollution to create a healthy and enjoyable environment for city inhabitants. In addition, the consequences of extreme weather on a city, such as flooding caused by typhoons or heavy snowfalls needs to be well managed to prevent adverse impacts to a cities citizens and businesses.

II. Research Analysis

2.1 In, The current scenario, as the air pollution is increasing, because of this pollution, we are going in open vehicle or in close vehicle such decision are taken.

2.2 Most of the time, I identify, in red signal, People are not follow signals and vehicle not stop. And occur accident .so, for decreasing accident such point of view, project is decided.

2.3 Even, in main area, the Road signage board is also not follow some people, in an over bridge area, the speed limit board, no horn sign board, this board also not follow people, hence such concept also include in this project.

2.4 also, driver in the vehicle according in electronics, system is follow, because of this accident is decreasing, speed is decreasing,

2.5 Some people are aware, some are not the engine keep on in red signal the fuel is waste in large amount when people are in signal. But some people save fuel hence environment cost is decreasing

III. Internet Of Thing

The Internet of Things (IoT) is interconnection everything being equal, living things and non-living things that are implanted with sensors, actuators, electronics, software and network availability and the capacity to exchange human-to-human or human-to-PC association. The IoT enables articles to be detected or controlled remotely crosswise over existing system framework, making open doors for more straightforward, and bringing about improved productivity, exactness and monetary advantage notwithstanding diminished human mediation. At the point when IoT is expanded with sensors and actuators, the innovation turns into an occasion of more board class of digital physical frameworks, which additionally incorporates advances.

How IoT works

An IoT ecosystem consists of web-enabled smart devices that use embedded processors, sensors and communication hardware to collect, send and act on data they acquire from their environments. IoT devices share the sensors data they collect by connecting to an IoT gateway or other edge device where data is either sent to analyzed or analyzed locally. Sometimes, these devices communicate with other related devices. The devices do most of the work without human intervention, although people can interact with the devices for instance, to set them up, give them instruction or access the data. The connectivity, networking and communication protocols used with web-enabled devices largely depend on the specific IoT applications deployed.

IV. Proposed System

The smart cities are the places where information and communication technologies are used to solve various issues or problems faced by citizens. But according to us a can only be called as smart if each and every component of city will be smart. It may be a citizen, city government and services provided by the government everything must to be smart. Hence with all those things in mind we have proposed system which will help in proper utilization of available resources of city.

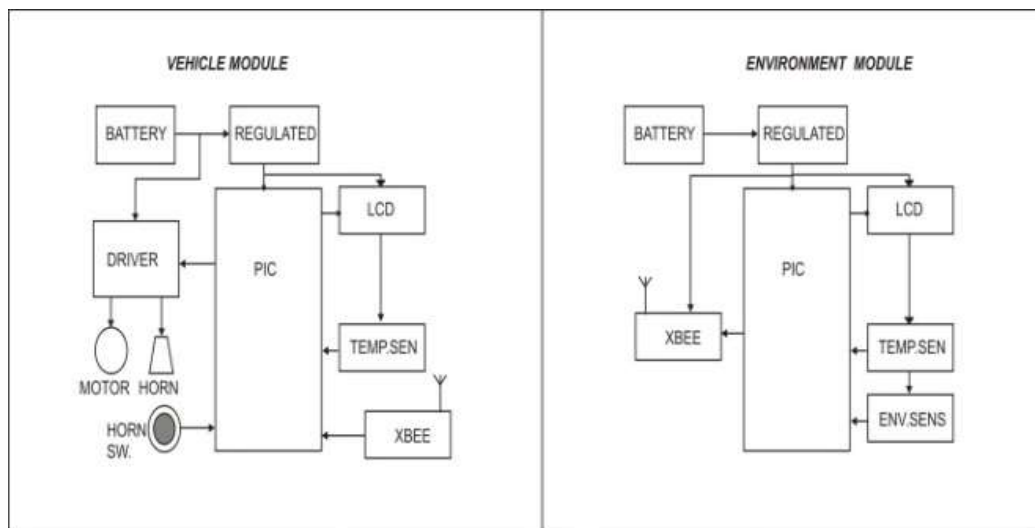

Fig.1 Block diagram of vehicle module and environment module.

The fig shows block diagram of vehicle module and Environment module. In vehicle module, the battery or source supply is given to regulated. The output of regulated voltage is 5v. This 5v is given also to LCD, PIC microcontroller, also in temperature sensor, temperature sensor read physical parameter and input is given to pic microcontroller. The Xbee is received from data. In this vehicle module there is horn switch, if horn is press, for receive microcontroller command, hence horn input is given to pic microcontroller. The microcontroller also continuously monitor DATA coming from XBEE and same will be display on LCD, regarding traffic jam, route diversions, etc. Driver IC through, horn is operated, Motor Driver IC is used to drive the 12v dc motor, because

PIC can give maximum 5v at it ports pin which is not sufficient to drive a 12v motor. Motor Driver amplify the signal coming from PIC to 12v also amplifies the current. In environment vehicle, the dust sensor is used, and all incoming data ,the xbee is transmitted ,and all data is displac in LCD ,when vehicle is pass in dust sensor, internally they work on photoelectric i.e.infrared LED they give pulse through microcontroller, as continue pulse is given,IRLED pass IR Rays, if there is no dust particle ,then photo detector receives IR Rays and gives voltage output to microcontroller. if there is dust particle then light scattered hence current deflection occurs and through OPAMP voltage is given to A to D converter input.

4.1 Components Required

The various components of system are described below along with their use and feature.

4.1.1) Ultrasonic non-contact sensor:



The sensors are used to collect data from surrounding. Level measurement can be performed via **Ultrasonic** or **Sonic** technology too. **Ultrasonic level Measurement** devices basically employ sound waves for detection of liquid level. They usually work over the frequency range between 20 kHz to 200 kHz. In this project we have used ultrasonic non contact sensor which gives information of distance or level contactless. **GP2Y1010AU0F** is a dust sensor by optical sensing system.

An infrared emitting diode (IRED) and an phototransistor are diagonally arranged into this device. It detects the reflected light of dust in air.

4.1.2)Xbee Module:

The xbee module is used as interface between PIC Microcontroller and server. We have used **Wi-Fi** module as PIC microcontroller in our system. It sends the data to android phone through the wireless media.

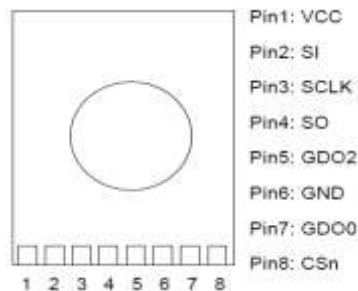

Pin #	Pin name	Pin Type	Description
1	VCC	Power	1.8~3.6V power supply
2	SI	Digital Input	Serial configuration interface, data input
3	SCLK	Digital Input	Serial configuration interface, clock input
4	SO	Digital Output	Serial configuration interface, clock input Optional general output pin when CSn is high
5	GDO2	Digital I/O	Digital output pin for general use >Test signals >FIFO status signals >Clear Channel indicator >Clock output, down-divided from Xosc >Serial output RX data
6	GND	Ground	
7	GDO0	Digital I/O	Digital output pin for general use: >Test signals >FIFO status signals >Clear Channel indicator >Clock output RX data >Serial output RX data >Serial input TX data Also used as analog test I/O for prototype/production testing
8	CSn	Digital Input	Serial configuration interface ,chip select

4.1.3) PIC microcontroller



PIC (Programmable Interface Controllers) microcontrollers are the world's smallest microcontrollers that can be programmed to carry out a huge range of tasks. These microcontrollers are found in many electronic devices such as phones, computer control systems, [Alarm systems](#), [Embedded systems](#), etc .In this project we have used 64 MHZ.

4.1.4)Relay Module:



The Relay Module Is Used For Operating Real Time Applications Like street lights. Basically it acts as switch to automatically turn on the devices when sensors exceed some threshold value. A relay is nothing more than a switch. A relay is an electromechanical switch. Simply put, a relay will be used for an alarm or remote start

installation for one or more of the four purposes:

- o To turn something ON
- o To turn something OFF or disable something
- o To change the polarity of a wire
- o To increase the current supply of a wire.

As vehicle battery have 12v and microcontroller requires 5v hence for converting voltage I used regulator IC 7805, this regulator convert voltage from 6v to 28v to a 5v and apply to the Vcc pin of microcontroller.

Now, c2 is used as a filter capacitor which reduces noise (hysteresis) generated in vehicle. If this noise gets inserted in system voltage bus, there may be chances of many malfunctions taking place inside microcontroller executions.

C3 is used as a storage capacitor which stores 5v after regulation and provides to the circuit whenever regulator IC fails to give a constant 5V to the circuit.

Thereafter PIC requires to reset, as lot of garbage data will reside inside whenever we switch off the power of PIC, which will not allow to store any new data when PIC power starts. A resistance R1 and C1 is used as a Power- ON-Reset circuit. whenever power supply switch on, initially C1 remains discharged, which may pull the voltage coming from R1 i.e 5v towards Ground, hence PIC reset pin gets Digital 0 initially, and whenever the capacitor c1 charged through R1, it acts as an open circuit, which may cause the current flow through R1 to zero, hence no voltage drops across R1 and PIC reset pin gets a Digital 1

As most of the execution inside the PIC controller performs inside the Flip-Flop and F/F requires a clock pulse to store or Erase the data. Hence, a Crystal Oscillator is used to generate continuous clock pulses.

In LCD pin No: 3, VEE is contrast adjustment pin (1.2-1.8V) i.e, Pixels of character remain visible.

The ultrasonic sensor consists transmitter and receiver. trigger pin enable sound wave to transmit towards any object and revert back and received by receiver on ECHO pin. If temperature is normal then ultrasonic sensor checks distance and set value according to travel time of a sound wave. If distant from object is greater than 3metre then it is safe mode. If distant from object is less than 3mtr then horn automatic operated and if distant from object <2m then break apply to stop the vehicle.

The microcontroller also continuously monitor DATA coming from XBEE and same will be display on LCD, regarding traffic jam, route diversions, etc.,

If vehicle controller identifies school then pic sends speed slow down command to the engine(I used DC Motor as an engine in my Project)

If vehicle controller identify hospital, then pic sends speed slow down command to the engine simultaneously switch OFF the Horn also.

Motor Driver IC is used to drive the 12v dc motor, because PIC can give maximum 5v at its ports pin which is not sufficient to drive a 12v motor. Motor Driver amplifies the signal coming from PIC to 12v also amplifies the current.

A switch is used to turn ON/OFF the Horn.

In environment vehicle, the dust sensor is used, and all incoming data, the xbee is transmitted, and all data is displayed in LCD, when vehicle is pass in dust sensor, internally they work on photoelectric i.e.infrared LED they give pulse through microcontroller, as continue pulse is given,IRLED pass IR Rays, if there is no dust particle, then photo detector receives IR Rays and gives voltage output to microcontroller. If there is dust particle then light scattered hence current deflection occurs and through OPAMP voltage is given to A to D converter input.

V. Implementation

The proposed system is implemented as shown in following figure. It is the snapshot of the actual implanted project. The system is Fig



Fig 2.Vehicle Module



Fig 3.Environmental module

VI. Conclusion

The system developed by using Internet of Thing will provide the services like environmental parameter,air pollution .It will help in better utilization of available infrastructure facilities and thus provide a decent environment through the smart solutions. So the use of IoT is the best option to make city smart.

Reference

- [1]. NehaFirdaushRaun “Smart environment using internet of things (IOTS) - a review” Published in 2016 IEEE 7th Annual Information Technology, Electronics and Mobile Communication Conference (IEMCON)
- [2]. Madhvi A. Pradhan; SupriyaPatankar; AkshayShinde; VirendraShivarkar; PrashantPhadatare“IoT for smart city: Improving smart environment” 2017 .
- [3]. C. TejaswiniRoy ; D. Sri Lakshmi ; G. Anirudh Kumar ; H. N. Vishwas “International Conference On Smart Technologies For Smart Nation ” 2017
- [4]. AmanyAlnahdi; Shih-Hsi Liu “Mobile Internet of Things (MIoT) and Its Applications for Smart Environments” ,2017 IEEE International Congress on Internet of Things (ICIOT).
- [5]. NeeharikaCherukutota ;ShraddhaJadhav “Architectural framework of smart water meter reading system in IoT environment”,2016 International Conference on Communication and Signal Processing.
- [6]. Jih-Wei Wu ; Ding-Wei Chou ; Jehn-Ruey Jiang The Virtual Environment of Things (VEoT): A Framework for Integrating Smart Things into Networked Virtual Environments, 2014
- [7]. JaganathanVenkatesh ; BarisAksanli ; Christine S. Chan ; AlperSinanAkyurek ; TajanaSimunicRosing “Modular and Personalized Smart Health Application Design in a Smart City Environment”,2018 , Volume: 5 , Issue: 2

- [8]. A. VimalJerald; S. Albert Rabara; Daisy PremilaBai
"Secure IoT architecture for integrated smart services environment",2016.
- [9]. Jiang Lu ; Xingang Fu ; Ting Zhang "A smart system for face detection with spatial correlation improvement in IoT environment",2017 IEEE Smart World, Ubiquitous Intelligence
- [10]. Rajdeep Kumar Nath ; RajnishBajpai ; HimanshuThapliyal"IoT based indoor location detection system for smart home environment" ,2018 IEEE International Conference on Consumer Electronics (ICCE) Smart home environment
- [11]. A. Boubrima, W. Beackit, and H. Rivano, "A new WSN deployment approach for air pollution monitoring," in 14th IEEE Annual Consumer Communication and NetworkingConference (CCNC), NV, USA, Jan. 2017,
- [12]. P. Khunsongkiet, and E. Boonchieng, "Converting air quality monitoring low cost sensor data to digital value via mobileinterface," in 9th Biomedical Engineering InternationalConference (BMEiCON), LaungPrabang, Laos, Dec. 2017..
- [13]. J. Shah, and B. Mishra, "IoT enabled environmentalmonitoring system for smart cities," in International Conference on Internet of Things and Applications (IoTA),Pune, India, Jan. 2017.
- [14]. B. Braem, S. Latre, P. Leroux, P. Demeester, T. Coenen, and P. Ballon, "Designing a smart city playground: Real time airquality measurements and virtualization in the city of things testbed," in IEEE International Smart Cities Conference(ISC2), Trento, Italy, Sep. 2016..
- [15]. K. Zheng, S. Zhoa, Z. Yang, X. Xiong, and W. Xiang, "Design and implementation of LPWA-based air quality monitoring system," IEEE Access, vol. 4, 2017